

# HIP-MITSU

## DRUM MELTER SERIES DM 200

The drum melters series **DM 200** – produced by **HIP- MITSU** – enable the use of hot melt and reactive hot melt adhesives, butyls and sealants from 200 LITER (55 gallons) drums.

Furthermore drum melters series **DM 200** enable the use of a wide range of polymers with working temperatures up to 240 °C.

The machinee standardly equiped with by-pass, enables continuous and/or intermittent applications.

The drum melters series **DM 200** melt the adhesives "near the drum's surface" only : thanks to that the machine maintains cool and in a perfect status the remaining polymer, without thermal stress.

In case of using a reactive hot melt adhesive (PUR), the machine preserves fully wholesome the adhesive for a long time.

In the **DM 200** can be installed up to two gear pumps, also with on-line filtering. Furthermore two different kinds of drums enable to maximize the melt rate in function of the adhesive to be used.

For continuous applications it's also available the "no-stop **HIP-MITSU** system", that removes down time for drum changing.



Specific anti-stick treatments have been applied on all surfaces in contact with the adhesive.

Security devices avoid danger of scalding for contact with high-temperature parts and surfaces.

Loading and unloading are simplified by a full automatic control installed in the machine.

Each pump can support one or two automatic hoses.

The standard configuration does not enable the machine to work in conditions of over- or under-temperature.

The display panel allows a simple programming of all working conditions and their monitoring on-line.

An appropriate design and the use of high forefront technology materials avoid possible deterioration of the adhesive in case of using reactive hot melt PUR.

Thanks to a complete control board - that can be quickly understood and easily customized by the user - all main indications of status can be controlled at distance.

Control and monitoring on-line of all thermo-regulated parts, with independent regulation of the temperature during the working and stand-by phases.

The display panel includes:

- All the regulation functions in Celsius or Fahrenheit of the working temperature of each single thermo-regulated part.
- The interface with the basic line and its emergency devices.
- The protection against the use of the machinery in over- or under-temperature situations.

The microprocessor cares for the control of all the temperatures thanks to a PID system setting the different temperatures with a precision to +/- 0.5° C (+/- 1° F). The PID operative status parameters can be easily programmed according to the different applications.

The main system's status conditions are signalled to the working operator by a "light tower" with four different colours or by an acoustic alarm with four different tones. The control processing system is provided with a weekly and daily timer that provides automatically for the management of the machine concerning the operating and stand by conditions.

Filters on-line, with a quick substitution, protect the system and the connected devices from any foreign body and guarantee as a matter of fact a perfect distribution of the adhesive.

The adhesive quantity distributed can be increased or reduced according to the variations of the line speed, adjusting automatically the RPM of the engine that acts upon the gear pump.

**OPTIONS**

- Profibus interface for easy integration with the production line control system (PLC); all the process data available for statistical process control / data logging, remote control of all functions or visualization of the process data.
- Modular additional temperature channels for using automatic guns, air heaters, manifold or other additional devices to be connected and synchronised to the machine.



Each gear pump provided with independent by pass



High melt rate capacity drum

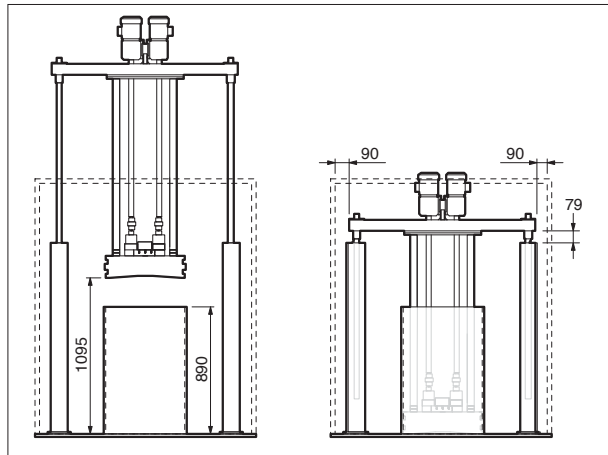

Dimensions

**TECHNICAL CHARACTERISTICS**

MODEL	DIMENSION L x W x H (mm)	WEIGHT (kg)	VOLTAGE	BASIC POWER CONSUMPTION (Watt) <sup>(1)</sup>	DRUM DIAMETER (mm)	TEMPERATURE SENSOR	DEGREE OF PROTECTION
<b>DM 200</b>	1.200 x 1.540 x 1.840/2.940 H	680 Kg	380V 50Hz 3 ph + N	26.000	571	PT100	IP55 ISO EN 294

<sup>(1)</sup> The value reported is indicative as it depends on the used configuration.



add value to your production

**HEAD OFFICE**

I - 31027 SPRESIANO (TV) Italy - Via A. Volta, 1  
Tel. + 39 0422 887.566 r.a. - Fax + 39 0422 887.337 - <http://www.hip-mitsu.com> e-mail: [info@hip-mitsu.com](mailto:info@hip-mitsu.com)